

Linear Translation Stages

Stepper & Servo, Leadscrew & Ballscrew Drives

HIGH FORCE

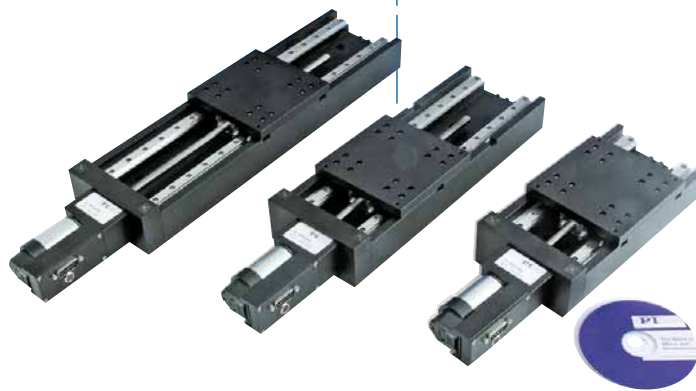

COMPACT



PRECISE

M-122 Miniature Precision Linear-Translation Stage

Fast & Compact with Direct Position Measurement

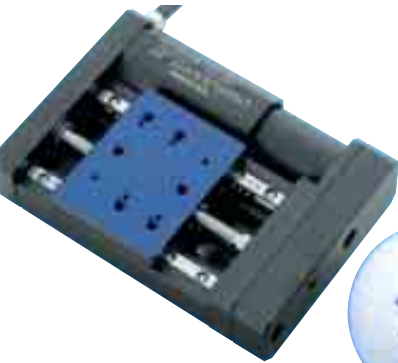

The M-122.2DD miniature translation stage features an optical linear encoder with 0.1 μm position resolution and a highly efficient ballscrew

- Travel Range 25 mm
- 0.1 μm Optical Linear Encoder for Highest Accuracy & Repeatability
- Min. Incremental Motion to 0.2 μm
- Max. Velocity 20 mm/s
- Cross-Roll Bearings
- Recirculating Ball Screw Drives Provide High Speeds & Long Lifetimes

The M-122 palm-top-sized translation stage combines small dimensions, high speeds and very high accuracy at a competitive price. It features a space-saving, folded drive train with the servo motor and drive screw side-by-side. Equipped with a non-contacting optical linear encoder and a preloaded, precision-ground, ball-screw, these stages can provide much higher accuracy and better repeatability than conventional stepper motor stages or rotary encoder-equipped servo motor stages.

Low Friction, High Speed, Maintenance-Free

Due to its low-friction, the backlash-free ball screw yields significantly higher mechanical

efficiency than leadscrews, and allows maintenance-free, high duty-cycle operation at high velocities up to 20 mm/sec.

XY and XYZ Combinations

M-122 stages can be combined to very compact XY and XYZ systems. The M-122.AP1 mounting bracket is available to mount the Z-axis.

Limit and Reference Switches

For the protection of your equipment, non-contact Hall-effect limit and reference switches are installed. The direction-sensing reference switch supports advanced automation applications with high precision.

Low Cost of Ownership

The combination of these positioners with the networkable, single-channel C-863 Mercury™ servo motor controller (s. p. 4-114) offers high performance for a very competitive price in both single- and multi-axis configurations. For multi-axis applications, the C-843 PC plug-in controller board with on-board servo amplifiers (s. p. 4-120) is another cost-effective alternative.

Ordering Information

M-122.2DD
High-Precision Translation Stage, 25 mm, Direct-Drive DC Motor, Ballscrew

Accessories

M-122.AP1
Angle bracket for vertical mounting of M-122 stages
Ask about custom designs

M-122.2DD dimensions in mm, 3 m cable, Sub-D connector 15-pin

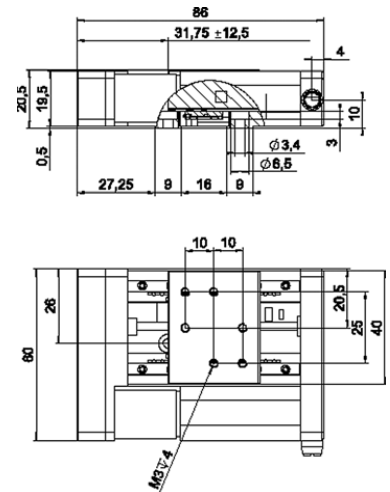

Technical Data

Model	M-122.2DD
Active axes	X
Motion and positioning	
Travel range	25 mm
Integrated sensor	Linear encoder
Sensor resolution	0.1 μm
Design resolution	0.1 μm
Min. incremental motion	0.2 μm
Backlash	0.2 μm
Unidirectional repeatability	0.15 μm
Pitch	$\pm 150 \mu\text{rad}$
Yaw	$\pm 150 \mu\text{rad}$
Max. velocity	20 mm/s
Origin repeatability	1 μm
Mechanical properties	
Drive screw	Recirculating ballscrew
Thread pitch	0.5 mm
Stiffness in motion direction	0.25 N/ μm
Max. load	50 N
Max. push/pull force	20 N
Max. lateral force	25 N
Drive properties	
Motor type	DC motor
Operating voltage	0 to $\pm 12 \text{ V}$
Electrical power	2.25 W
Limit and reference switches	Hall-effect
Miscellaneous	
Operating temperature range	-20 to +65
Material	Aluminum, steel
Dimensions	86 x 60 x 20.5 mm
Mass	0.3 kg
Recommended controller/driver	C-863 (single-axis) C-843 PCI board (up to 4 axes)

Application Examples

- Photonics packaging
- Fiber positioning
- Metrology
- Quality assurance testing
- Testing equipment
- Micromachining

M-605 High-Accuracy Linear Translation Stage w/ Linear Encoder

Ultra-Compact, with Direct Position Measurement



M-605.2DD high precision translation stage

- **Integrated 0.1 μm Linear Encoder for Highest Accuracy**
- **Travel Ranges 25 mm (1") and 50 mm (2")**
- **Max. Velocity 50 mm/s with ActiveDrive Motor**
- **High Load Capacity up to 30 kg**
- **Zero-Backlash Recirculating Ballscrews**
- **Non-contact Limit and Reference Switches**
- **Stress-Relieved Aluminum Base for Highest Stability**
- **Flexible Bellows Protects the Mechanics from Dust and Spray**
- **XY & XYZ Combinations Possible**
- **MTBF >20,000 h**

M-605 series translation stages are designed to meet the most demanding positioning requirements in applications where space is limited.

They feature a space-saving design with the ballscrew side-by-side to the motor and an extremely flat, precision-ma-

chined base of high-density, stress-relieved aluminum providing exceptional stability and minimum weight.

Integrated Linear Scale Encoder

For highest accuracy and repeatability, M-605 stages are equipped with integrated linear-scale encoders (direct metrology) providing 0.1 μm minimum incremental motion and 1 μm full-travel accuracy.

Heavy Duty and Maintenance Free

All models are equipped with high-precision linear guiding rails and recirculating ball bearings. The choice of components and careful mounting guarantees high load capacity, longer lifetime and high guiding accuracy.

Ballscrews for High Speed, Precision and Lifetime

The precision-ground ballscrew is maintenance-free and pre-loaded to eliminate mechanical play. Its significantly reduced friction, compared to conventional leadscrews, allows for higher velocity, lower power consumption and longer lifetime.

A flexible bellows protects the mechanics from dust and spray.

ActiveDrive

For maximum dynamic performance, the M-605 series stages are equipped with the highly efficient ActiveDrive direct-drive system, which can achieve speeds of up to 50 mm/s. The ActiveDrive design, developed by PI, features a high-efficiency PWM (pulse width modulation) servo-amplifier mounted side-by-side with the DC motor and offers several advantages:

- Increased efficiency, by eliminating power losses between the amplifier and motor
- Reduced cost of ownership and improved reliability, because no external driver is required
- Elimination of PWM amplifier noise radiation, by mounting the amplifier and

Ordering Information

M-605.1DD
Compact Precision Linear Stage, 25 mm, 0.1 μm Linear Encoder, ActiveDrive DC Motor

M-605.2DD
Compact Precision Linear Stage, 50 mm, 0.1 μm Linear Encoder, ActiveDrive DC Motor

Accessories:

M-605.AV1
Angle Bracket for Vertical Mount of M-605 on M-605

M-110.01

Adapter Plate for Horizontal Mount of M-605 on Honeycomb Tables, M-400- and M-500 Series Translation Stages and Several Rotation Stages

Ask about custom designs!

motor together in a single, electrically shielded case

Limit and Reference Switches

For the protection of your equipment, non-contact Hall-effect limit and reference switches are installed. The direction-sensing reference switch supports advanced automation applications with high precision.

Precision Assembly

Each M-605 stage is precision assembled and optimized using laser interferometers for performance testing.



M-605.2DD XYZ-combination

Application Examples

- R&D
- Semiconductor testing
- Mass storage device testing
- Metrology
- Photonics packaging
- Quality assurance testing
- Precision Linear Motion Control

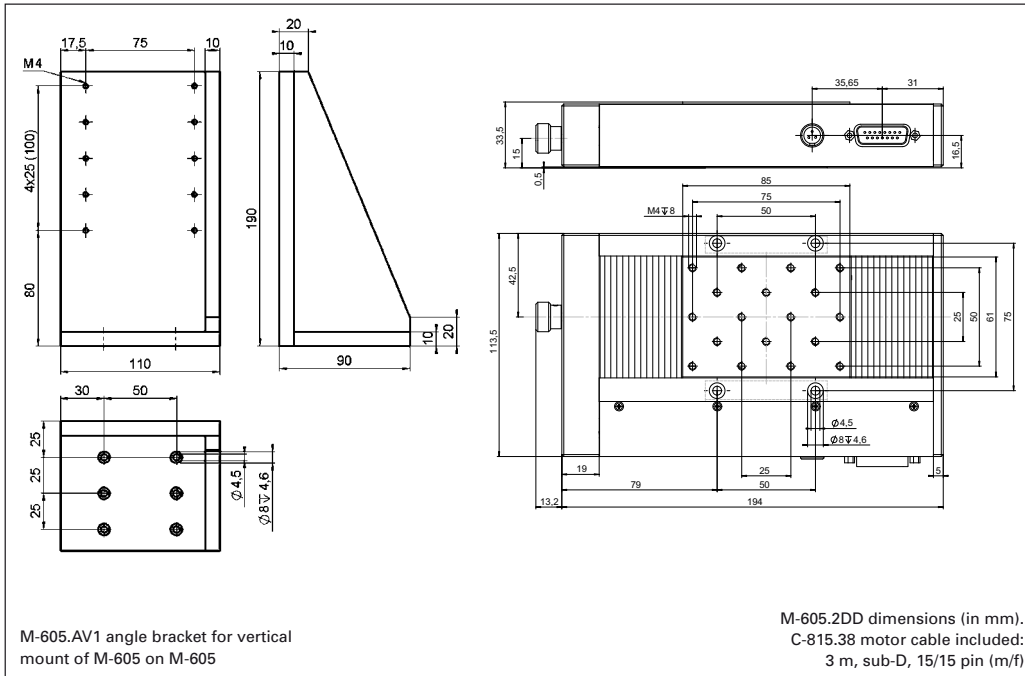

Technical Data

Model	M-605.1DD	M-605.2DD	Units
Active Axes	X	X	
Motion and positioning			
Travel range	25	50	mm
Integrated sensor	Linear encoder	Linear encoder	
Sensor resolution	0.1	0.1	μm
Design resolution	0.1	0.1	μm
Min. incremental motion	0.3	0.3	μm
Unidirectional repeatability	0.1	0.1	μm
Bidirectional repeatability	0.2	0.2	μm
Accuracy	1	1	μm
Pitch	±30	±30	μrad
Yaw	±30	±30	μrad
Max. velocity	50	50	mm/s
Origin repeatability	1	1	μm
Mechanical properties			
Thread pitch	1	1	mm
Max. load	300	300	N
Max. push / pull force	20 / 20	20 / 20	N
Max. lateral force	100	100	N
Drive properties			
Motor type	ActiveDrive DC Motor	ActiveDrive DC Motor	
Operating voltage	24 (PWM)	24 (PWM)	V
Electrical power	6	6	W
Limit and reference switches	Hall-effect	Hall-effect	
Miscellaneous			
Operating temperature range	-20 to +65	-20 to +65	°C
Material	Al (black anodized)	Al (black anodized)	
Mass	1.5	1.8	kg
Recommended controller/driver	C-863 single-axis C-843 PCI board (up to 4 axes)	C-863 single-axis (p. 4-114) C-843 PCI board (p. 4-120) (up to 4 axes)	

High-Load Precision Linear Translation Stage Series

Cost-Effective, Large Choice of Drives & Travel Ranges, Loads to 50 kg



M-413 linear stage versions (from right: the M-413.1PD, M-413.2PD and M-413.3PD provide travel ranges from 100 to 300 mm (CD for size comparison)

- For Cost-Sensitive Precision Positioning Applications
- Travel Ranges 100 to 300 mm
- Resolution to 0.018 μm
- Min. Incremental Motion to 0.1 μm
- Preloaded Precision Leadscrew or Recirculating Ball Screw Drives Provide High Speeds & Long Lifetimes
- Stress-Relieved Aluminum Base for Highest Stability
- Vacuum-Compatible Versions Available
- M-403 and M-404 Versions for Reduced Load Requirements

The M-413 and M-414 linear translation stage series provide cost effective solutions for precision positioning of higher loads up to 50 kg over travel ranges up to 300 mm.

They are designed with a precision-machined, high-density, stress-relieved aluminum base for exceptional stability and robustness. The highly precise M-413 drive includes a preload-ed leadscrew, providing a minimum incremental motion of 0.2 μm .

High Resolution Ball Screws & Lead Screws

For higher velocities and a long lifetime the M-414 versions fea-

Application Examples

- Automation
- R&D
- Semiconductor technology
- Metrology
- Quality assurance testing

ture a low-friction ball screw offering a minimum incremental motion down to 0.1 μm .

Three motor drive options allow the optimum adaptation to the requirements of different automation applications.

M-413s and M-414s are available in 3 lengths providing travel ranges from 100 to 300 mm. The stages can carry up to 50 kg and push/pull up to 50 N. Special versions for vacuum applications are available (see ordering information).

Maintenance-Free, High Guiding Precision

All models are equipped with high-precision linear guiding rails and recirculating ball bearings. The recirculating ball bearings are maintenance free and immune to cage migration. The choice of components and careful mounting guarantees high load capacity, longer lifetime and high guiding accuracy. Additionally the bearings are

Ordering Information

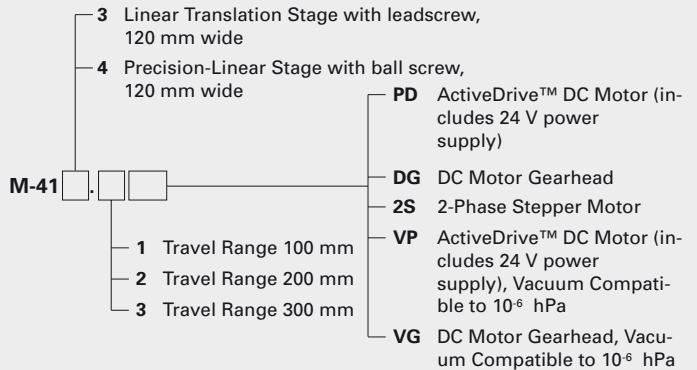

polished to guide the carriage with optimum straightness and flatness.

Low Cost of System Ownership

The combination of these stages with the networkable single-axis C-863 Mercury™ (see p. 4-114) and C-663 Mercury™ Step (see p. 4-112) controllers offers high performance for a very competitive price in both single and multi-axis configurations. Alternatively, the C-843 motion controller PCI card with on-board servo amplifiers (!) is available.

Three Motor Drive Options

M-41x.xPD high-speed versions come equipped with the high-performance ActiveDrive™ system. The ActiveDrive™ design, developed by PI, features a high-efficiency PWM (pulse width modulation) servo-amplifier mounted side-by-side with the DC motor and offers several advantages:

- Increased efficiency, by eliminating power losses between the amplifier and motor
- Reduced cost of ownership and improved reliability, because no external driver is required
- Elimination of PWM amplifier noise radiation, by mounting the amplifier and

motor together in a single, electrically shielded case

M41x.xDG models are equipped with a DC motor with a low-backlash gearhead and a shaft-mounted optical encoder to give a minimum incremental motion of 0.1 μm .

M-41x.x2S models feature a cost-effective direct-drive, 2-phase stepper motor, providing very smooth operation and a resolution of 0.2 μm .

Limit and Reference Switches

For the protection of your equipment, non-contact Hall-effect limit and reference switches are installed. The direction-sensing reference switch supports advanced automation applications with high precision.

Other Family Members

The M-403/M-413 and M-404/M-414 series of linear stages form a modular system. The M-403 is the basic family, providing travel ranges from 25 to 200 mm. M-413 is designed for higher loads with travel ranges from 100 to 300 mm. The M-404 and M-414 stages have the same travel ranges and load capacities, but offer higher precision and more speed.

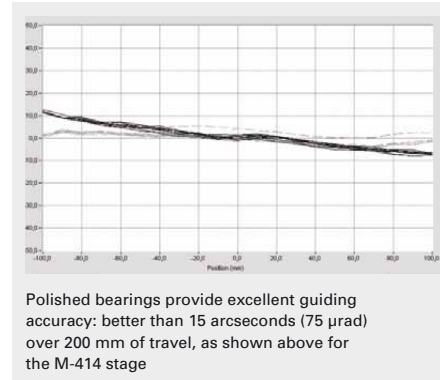
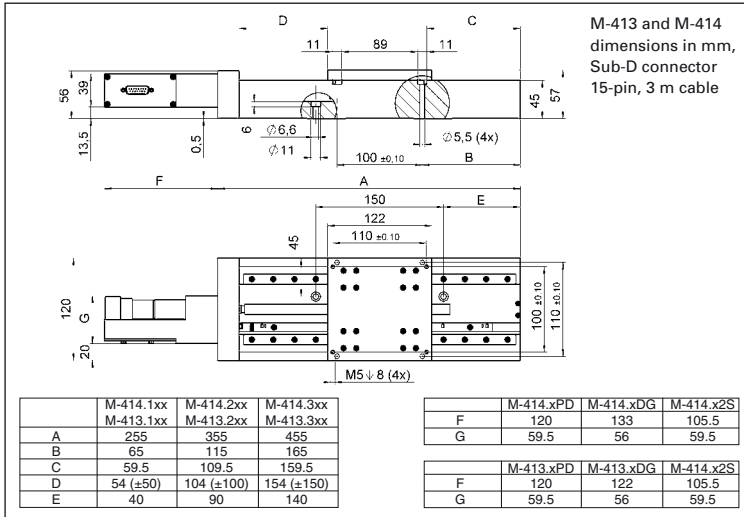

Technical Data

Model	M-414.xPD	M-414.xDG	M-414.x2S	M-413.xPD	M-413.xDG	M-413.x2S	Units
Motion and positioning							
Travel range	for all models: 100 / 200 / 300 mm (see Ordering Information)						
Integrated sensor	Rotary encoder	Rotary encoder	–	Rotary encoder	Rotary encoder	–	
Sensor resolution	4000	2000	–	4000	2000	–	cts/rev.
Design resolution	0.5	0.023	0.31	0.25	0.018	0.16	µm
Min. incremental motion	0.5	0.1	0.4	0.25	0.2	0.2	µm
Backlash	0.5	4	2	6	10	6	µm
Unidirectional repeatability	0.5	1	1	1	1	1	µm
Pitch**	±100	±100	±100	±300	±300	±300	µrad
Yaw**	±100	±100	±100	±300	±300	±300	µrad
Max. velocity	100	3	6	10 [#]	2.5	3	mm/s
Origin repeatability	1	1	1	1	1	1	µm
Mechanical properties							
Spindle	Recirculating ballscrew	Recirculating ballscrew	Recirculating ballscrew	Leadscrew	Leadscrew	Leadscrew	
Spindle pitch	2	2	2	1	1	1	mm
Gear ratio	–	42.92063:1	–	–	28.44444:1	–	
Motor resolution	–	–	6400*	–	–	6400*	steps/rev.
Stiffness in motion direction	6000	6000	6000	6000	6000	6000	N/µm
Max. load	500	500	500	500	500	500	N
Max. push/pull force	200	200	150	50	50	50	N
Max. lateral force	200	200	200	200	200	200	N
Drive properties							
Motor type	ActiveDrive™ DC motor	DC motor, gearhead	2-phase stepper motor*	ActiveDrive™ DC motor	DC motor, gearhead	2-phase stepper motor*	
Operating voltage	24	0–12	24	24	0–12	24	V
Electrical power	70	3.6	4.8	70	3.6	4.8	W
Torque	80	3	200	80	3	200	Ncm
Limit and reference switches	Hall-effect	Hall-effect	Hall-effect	Hall-effect	Hall-effect	Hall-effect	
Miscellaneous							
Operating temperature range	-20 to +65	-20 to +65	-20 to +65	-20 to +65	-20 to +65	-20 to +65	°C
Material	for all models: Aluminum (black anodized)						
Mass (depends on dimensions/travel range)	4.4 / 5.4 / 6.6	4.2 / 5.2 / 6.4	4.4 / 5.4 / 6.6	4.4 / 5.4 / 6.6	4.2 / 5.2 / 6.4	4.4 / 5.4 / 6.6	kg
Recommended controller/driver	C-863 (single-axis) C-843 PCI board (up to 4 axes)	C-863 (single-axis) C-843 PCI board (up to 4 axes)	C-663 (single-axis)	C-863 (single-axis) C-843 PCI board (up to 4 axes)	C-863 (single-axis) C-843 PCI board (up to 4 axes)	C-663 (single-axis)	

Data for vacuum versions may differ.

*2-phase stepper motor, 24 V chopper voltage, max. 0.8 A/phase, 400 full steps/rev., motor resolution with C-663 stepper motor controller

[#]Max. recommended velocity

**For travels >100 mm, the pitch/yaw value is valid for every 100 mm.

Program Overview

- Piezo Ceramic Actuators & Motors
- Piezo Nanopositioning Systems and Scanners
- Active Optics / Tip-Tilt Platforms
- Capacitive Nanometrology Sensors
- Piezo Electronics: Amplifiers and Controllers
- Hexapod 6-Axis Positioners / Robots
- Micropositioning Stages & Actuators
- Photonics Alignment Systems, Solutions for Telecommunications
- Motor Controllers
- Ultrasonic Linear Motors

Request or download the complete PI Nanopositioning & Piezo Actuator Catalog



USA (East) & CANADA

PI (Physik Instrumente) L.P.
 16 Albert St.
 Auburn, MA 01501
 Tel: +1 (508) 832 3456
 Fax: +1 (508) 832 0506
 info@pi-usa.us
 www.pi-usa.us

JAPAN

PI Japan Co., Ltd.
 Akebono-cho 2-38-5
 Tachikawa-shi
 J-Tokyo 190
 Tel: +81 (42) 526 7300
 Fax: +81 (42) 526 7301
 info@pi-japan.jp
 www.pi-japan.jp

CHINA

Physik Instrumente (PI Shanghai) Co., Ltd.
 Building No. 7-301
 Longdong Avenue 3000
 201203 Shanghai, China
 Tel: +86 (21) 687 900 08
 Fax: +86 (21) 687 900 98
 info@pi-china.cn
 www.pi-china.cn

FRANCE

PI France S.A.S
 244 bis, avenue Max Dormoy
 92120 Montrouge
 Tel: +33 (1) 55 22 60 00
 Fax: +33 (1) 41 48 56 62
 info.france@pi.ws
 www.pi-france.fr

GERMANY

Physik Instrumente (PI) GmbH & Co. KG
 Auf der Römerstr. 1
 D-76228 Karlsruhe/Palmbach
 Tel: +49 (721) 4846-0
 Fax: +49 (721) 4846-100
 info@pi.ws · www.pi.ws

USA (West) & MEXICO

PI (Physik Instrumente) L.P.
 5420 Trabuco Rd., Suite 100
 Irvine, CA 92620
 Tel: +1 (949) 679 9191
 Fax: +1 (949) 679 9292
 info@pi-usa.us
 www.pi-usa.us

PI Japan Co., Ltd.
 Hanahara Dai-ni Building, #703
 4-11-27 Nishinakajima,
 Yodogawa-ku, Osaka-shi
 J-Osaka 532
 Tel: +81 (6) 6304 5605
 Fax: +81 (6) 6304 5606
 info@pi-japan.jp
 www.pi-japan.jp

UK & IRELAND

PI (Physik Instrumente) Ltd.
 Trent House
 University Way,
 Cranfield Technology Park,
 Cranfield,
 Bedford MK43 0AN
 Tel: +44 (1234) 756 360
 Fax: +44 (1234) 756 369
 uk@pi.ws
 www.physikinstrumente.co.uk

ITALY

Physik Instrumente (PI) S.r.l.
 Via G. Marconi, 28
 I-20091 Bresso (MI)
 Tel: +39 (02) 665 011 01
 Fax: +39 (02) 873 859 16
 info@pionline.it
 www.pionline.it